



OPERATING INSTRUCTIONS,
PARTS LIST
MAINTENANCE PROCEDURES
CONSOLIDATED SEWING
MACHINE CORP.

Model
733R-5

EXTRA HEAVY DUTY
LONG ARM
SINGLE NEEDLE
DROP FEED
ALTERNATING PRESSER FEET
LOCKSTITCH MACHINE

CONSOLIDATED SEWING MACHINE CORP.
COPYRIGHT © 1989 CONSOLIDATED SEWING MACHINE CORPORATION

INTRODUCTION — CONSEW MODEL 733R-5

Consew Model 733R-5 is a single needle, flatbed, type 301 stitch, reverse feed, industrial sewing machine used in the fabrication and repair of aerial delivery equipment.

Consew Model 733R-5 is capable of sewing fabrics that range from heavy cotton and nylon duck to multiple layers of heavy webbing.

Consew Model 733R-5 is able to fabricate and install personnel—, cargo— and extraction—parachutes, bridle loops, locking stow loops, harnesses and multiple layer heavy webbing splices.

Preventive Maintenance

Machines should be kept covered when not in operation to prevent dust and dirt accumulation which, when allowed to build up, mixes with oil and becomes caked on the machine.

After use, sewing machines should be wiped down with oil and a soft cloth before covering.

Once a week the inside of the machine and the motor should be blown out with shop air if available. If shop air is not available, clean with a soft bristle brush.

CAUTION: USE EYE PROTECTION WHEN USING SHOP AIR.

Once a year the machine should be cleaned with a solvent such as Freon, then immediately oiled thoroughly to prevent rust and corrosion.

CAUTION: ENSURE GOOD VENTILATION WHEN USING SOLVENTS.

When the machines are in constant use they should be oiled at least twice daily. Using the proper oil is of utmost importance. For lubrication of the machine, only good quality sewing machine oil should be used.

- a. Oiling points are shown in Figures 10 and 11.
- b. Use one drop at each oiling point.

SECTION II OPERATING INSTRUCTIONS AND MAINTENANCE PROCEDURES

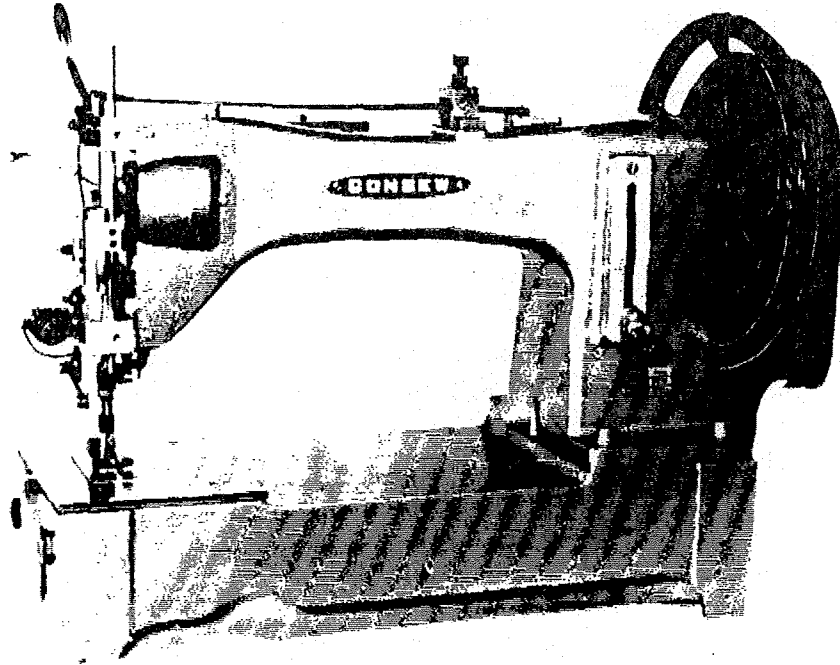

Characteristics and Capacity

The CONSEW Model 733R-5 single needle, extra heavy duty lockstitch machine is designed for sewing canvas, tents, sails, harnesses, safety belts, webbing and similar products.

It is equipped with alternating pressers, drop feed and a long-beak oscillating shuttle on a horizontal axis. It has a clearance of 25.4mm (1") under the presser foot. Clearance, on bed, at right of needle is 413mm (16 $\frac{1}{4}$ ") and length of bed 655mm (25 $\frac{3}{4}$ ")

The machine is equipped with a stitching reverse lever which also regulates stitches in length from 3 to 13mm (2 to 8 stitches per inch).

Alternating pressers consist of a vibrating presser foot and a lifting presser foot working in combination. In operation, the pressers alternately press down on the material, the vibrating presser working in unison with the feed, so that there is no slipping of the two or more plies of material which are being sewn. Additional features include pedal operated presser foot lift and reverse. The maximum operating speed is 550 stitches per minute. The balance wheel always rotates towards the operator.

THREAD AND NEEDLE SELECTION

THREAD

Left twist thread should be used in the needle. For the bobbin, either right twist or left twist can be used.

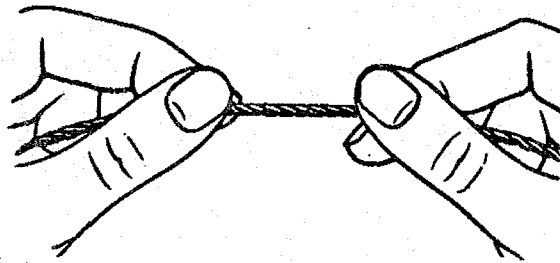

Fig. 1 How to determine the twist

Hold the thread as shown in Fig. 1. Turn the thread over toward you between the thumb and forefinger of the right hand. If left twist, the strands will wind tighter. If right twist, the strands will unravel.

NEEDLE

Needles recommended for Consew machine Model 733R-5 are as follows:

For Cloth

Schmetz — 1000 Series available in sizes 230, 250, 280, and 300

Schmetz — 1000H Series available in sizes 160, 200, 230,
250, 280, 300, 330

For Leather (Special orders only)

Schmetz - J.003D Series, triangular point, available in sizes 230, 250, 280
Schmetz - 1000DB1 Series - wide diamond point available in sizes 280
Schmetz - 1000LL Series, narrow twist point, available in sizes 250, 280
Schmetz - J.000LR Series, narrow reverse twist point, available in sizes 300
Schmetz- 1000.Q Series, square point, available in sizes 280, 300

The size of the needle to be used depends upon the size of the thread which must pass freely through the eye of the needle.

Do not use rough or uneven thread or thread which passes with difficulty through the needle eye, as such thread will interfere with the successful use of the machine.

TO REMOVE THE BOBBIN

Rotate the balance wheel bringing the needle bar to its lowest position. Then with the curved part of the shuttle cylinder opener t35225, which should conform to the curve of the shuttle, as shown in Fig. 2, insert the small end of the shuttle cylinder opener into Slot A in the spring latch under the shuttle cylinder (Fig. 2).

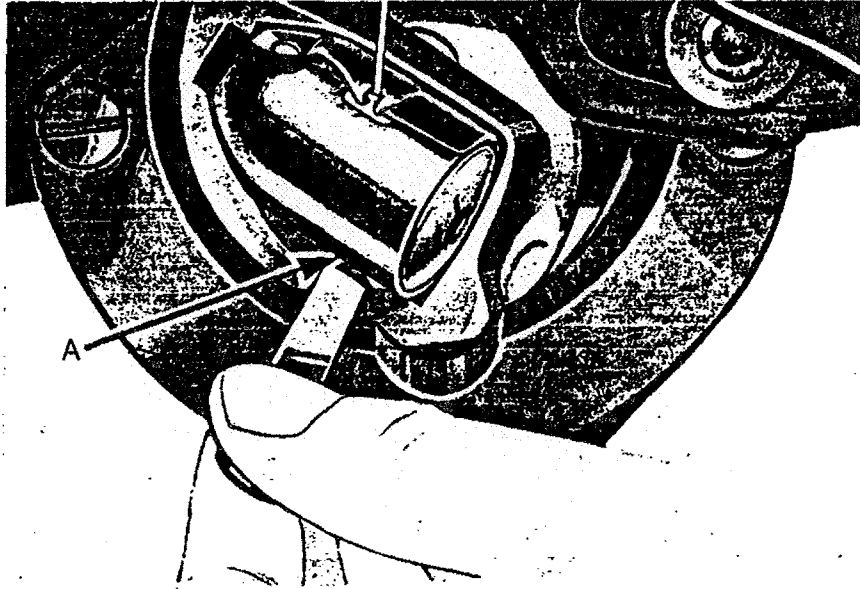

Fig. 2 use of Shuttle Cylinder Opener (35225)

4. WINDING BOBBINS

The bobbin winder is mounted on the table top as shown in Fig. 3 with its pulley in front of the driving belt so that the pulley will separate from the belt after the bobbin has been wound with sufficient thread.

Push the bobbin on the bobbin spindle (1, Fig. 3) as far as it will go. Pass the thread from thread stand downward through the eye in the tension bracket. Then between and around the back of the tension discs, bring the thread forward toward the bobbin and wind from below in clockwise direction several times around the bobbin. Push bobbin winder lever (3, Fig. 3) downward until the wheel (2, Fig. 3) contacts the drive belt and start the machine.

After bobbin is filled with thread, release will cause the wheel to disengage from the belt and winding will stop.

Cut the thread and remove the bobbin from the bobbin spindle.

The adjustment screw (5, Fig. 3) can be turned in or out to increase or decrease the amount of the thread wound on the bobbin.

When fine thread is wound on bobbins, use light tension. It is regulated by turning the knurled nut (6, Fig. 3) on the tension bracket at the rear of the bobbin winder.

Bobbin can be wound while the machine is sewing.

If the thread does not wind evenly on bobbins, loosen the screw (4, Fig. 3) and move the bracket to the right or left as required, then tighten the screw.

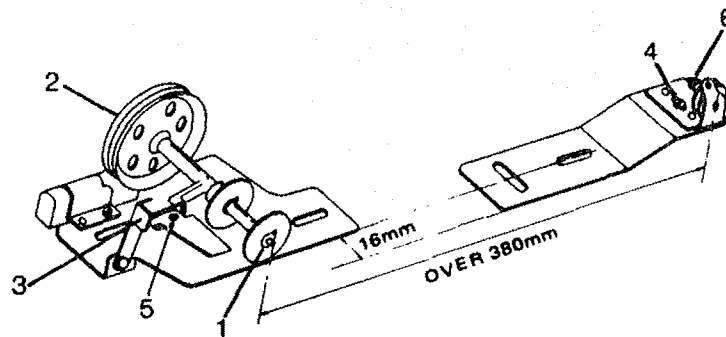

Fig. 3, winding Bobbins

5. TO REPLACE THE BOBBIN AND THREAD THE SHUTTLE

Hold the bobbin between the thumb and index finger of the left hand, at the same time the thread is drawing off from the underside toward the right as shown in Fig. 4. Place the bobbin in the cylinder as far as it will go, draw the thread in the slot B, Fig. 4 in the cylinder and under the tension spring, then into the delivery eye A, Fig. 4, then push the cylinder back until it is locked by the spring latch, and allow about 3 inches of thread to hang free from the shuttle Fig. 5 so that it can be drawn up through the throat plate, as noted in Fig. 8.

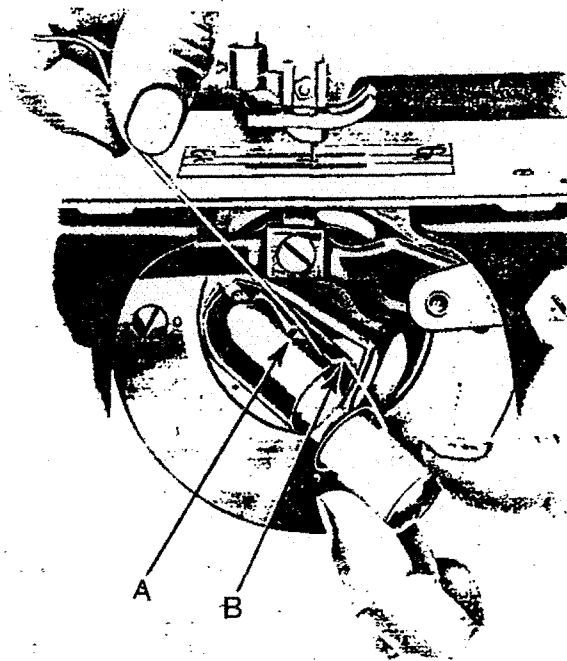

Fig. 4 Bobbin Replacement and Threading the Shuttle

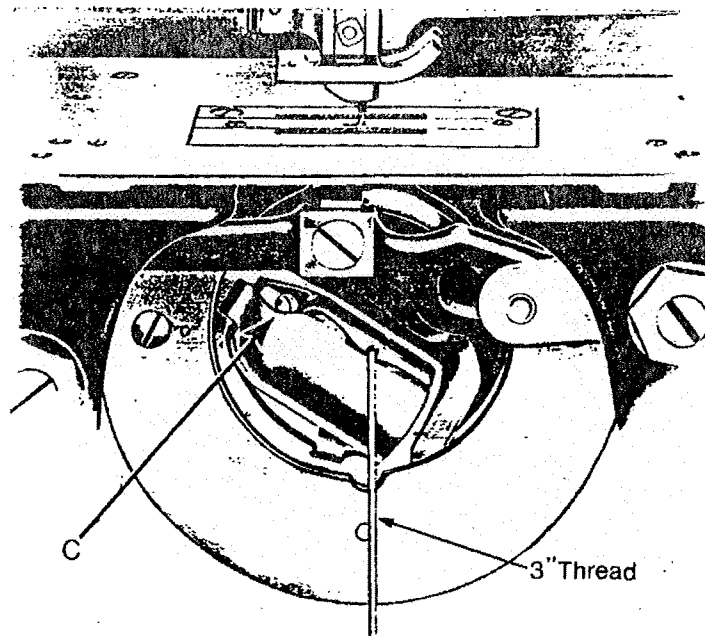

Fig. 5 Bobbin replaced and Shuttle threaded

6. TO SET THE NEEDLE

Rotate the balance wheel until the needle bar has reached its highest position. Loosen the set screw in the needle clamp and place the needle up into the clamp as far as it will go. The long groove of the needle must be facing left and the eye in line with the arm of the machine. Then tighten the set screw.

7. TO THREAD THE NEEDLE

With operator facing front of machine, turn balance wheel, until the thread take-up lever, (Fig. 6) reaches its highest position.

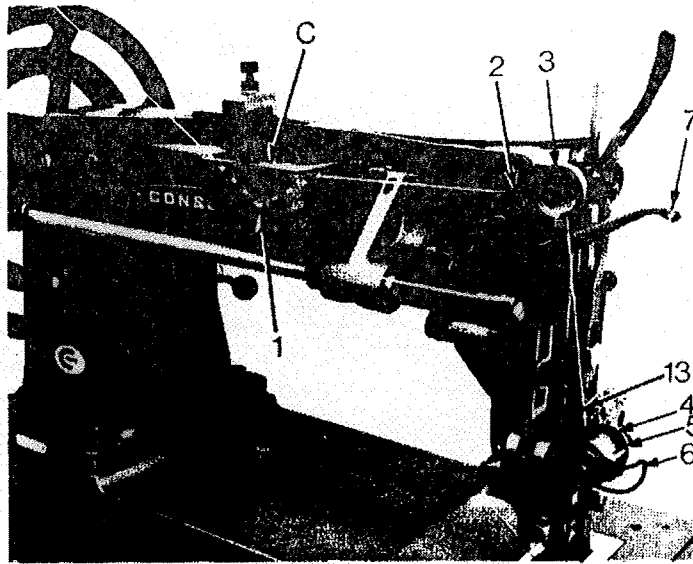

Fig. 6 Threading the Needle

Open the lid of Cup C; pass the thread from the cotton stand downward through the hole in the right side of cup, then through the thread post 1 under the lid, then through the hole in the left side of cup. Then close the lid and pass the thread through the thread guide 2, over from right to left between the thread retainer discs 3, down under and from thread guide 13 to let around the tension wheel 4, Into the

loop of the thread take-up spring 5, under the staple 6, Figs. 6 and 7, up and from back to front through the hole 7, in the thread take-up lever, down through the thread guide 8,

Fig. 7 into the slot 9 in the vibrating presser bar, into thread guide 10 on the needle clamp, and from left to right through the eye of the needle 11 then pass the thread down through the hole in the lifting presser foot 12. Draw about four inches of thread through the hole of the lifting presser foot with which to pull up the bobbin thread as shown in

Fig. 8.

Note: If thread lubrication is not required, omit thread from cup C Fig. 6 and start threading machine at thread guide 2 (Fig. 6.)

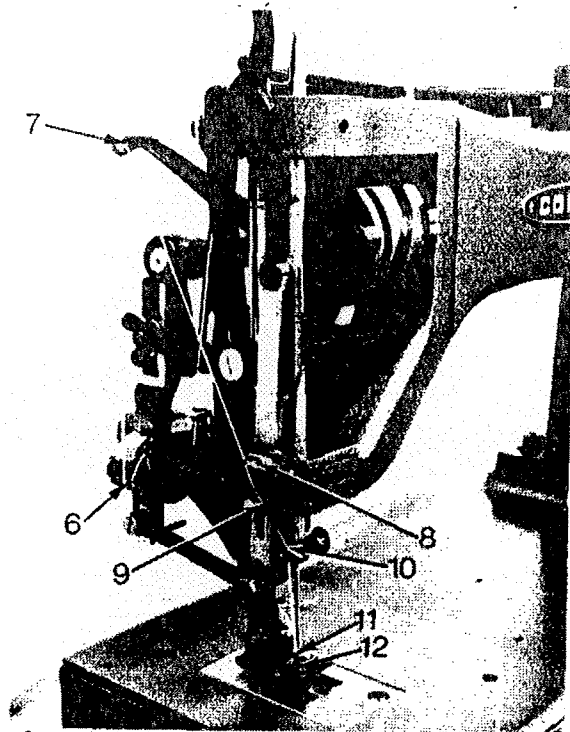

Fig. 7 Threading the Needle

B. TO PREPARE FOR SEWING

With the left hand hold the end of the needle thread, leaving it slack from the hand to the needle. Turn the balance wheel until the needle moves down and up again to its highest position, thus catching the bobbin thread; draw up the needle thread and the bobbin thread will come up with it through the hole in the throat plate (see Fig. 8) Lay both threads back under the presser feet.

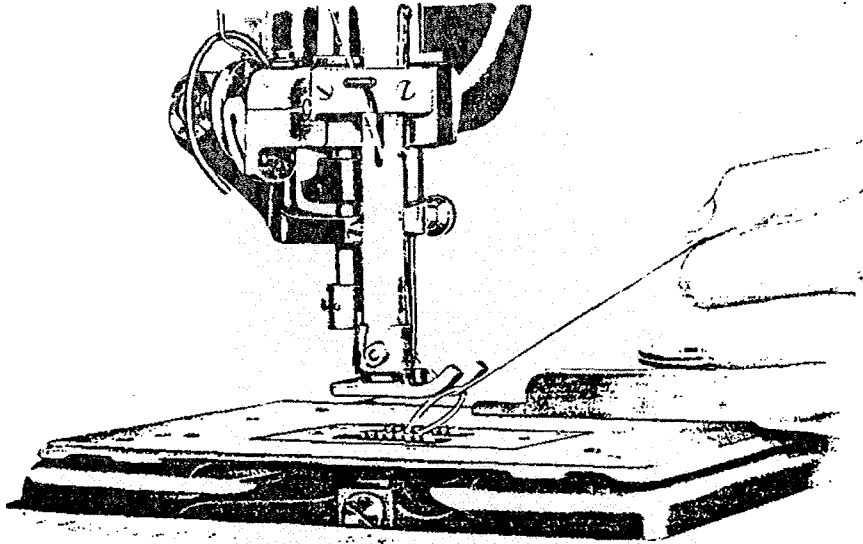

Fig. 8 Drawing up the Bobbin Thread

9. TO COMMENCE SEWING

Place the material beneath the presser feet, lower the presser feet and turn the balance wheel over toward you to begin sewing.

10. TO REMOVE THE WORK

Stop the machine with the thread take-up lever at rest in its highest position; draw about three inches of thread through the thread retaining discs, raise the presser feet, draw the work back and cut the threads close to the goods. Leave the ends of the threads under the presser feet.

11. REGULATING THE THREAD TENSIONS

For ordinary stitching, the tension of the needle and bobbin threads should be equal so as to lock both threads in the center of the fabric. If the tension on either thread is stronger than on the other, imperfect stitching will be the result.

If the tension on the needle thread is greater than that on the lower thread, it will be straight along the upper surface of the fabric.

If the tension on the bobbin thread is greater than that on the needle thread, the bobbin thread will lie straight along the underside of the fabric.



Perfect Stitch



Tight Needle Thread Tension



Loose Needle Thread Tension

Fig. 9

- A. The tension on the needle thread is regulated by the thumb nut H Fig. 11 at the front of the thread retaining discs and the thumb nut J Fig. 11 at the front of the tension wheel. The tension on the thread retaining discs should be only enough to cause the tension wheel to turn when the thread is taken from the spool.

B. The tension on the bobbin thread is regulated by the screw C Fig. 5 which holds the tension spring to the cylinder. To increase the tension, turn the screw to the right. To decrease the tension, turn the screw to the left.

12. TO REGULATE THE LENGTH OF STITCH AND REVERSE LEVER

The length of stitch is regulated by loosening the serrated nut on the reverse lever G Fig. 10 in the slot on the front of the upright part of the arm. To lengthen the stitch, move the lever downward. To shorten the stitch, move the lever upward and then tighten the nut.

When making reverse stitch move the lever upward as far as it will go.

13. TO REGULATE THE PRESSURE ON THE MATERIAL

The pressure on the material is regulated by means of the hexagon head screw D, Fig. 10. Loosen the hexagon lock nut, E, Fig. 10 and turn the screw 1) to the right to increase the pressure or to the left to decrease the pressure. When the desired pressure has been obtained, hold the screw D with a wrench to keep it from turning while the lock nut (E) is being tightened against the bracket (F).

The pressure should be only heavy enough to enable the feed to move the work along evenly, and to prevent the work from rising with the needle.

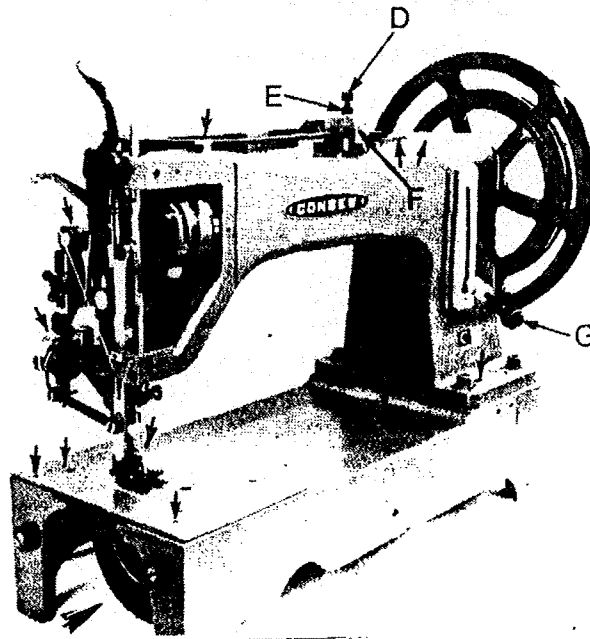

Fig. 10 Oiling Points at Front of Machine

14. TO OIL THE MACHINE

To insure easy running and prevent unnecessary wear of the machine, oil all parts which are in movable contact. When the machine is in continuous use, oil should be applied frequently. The places where the machine should be oiled are indicated in Figs. 10 and 11 by arrows pointing to the oil holes and bearings. **Important Note:** The oil holes on the machine are indicated by a red circle around the oil hole. Oil should be regularly applied to the shuttle race.

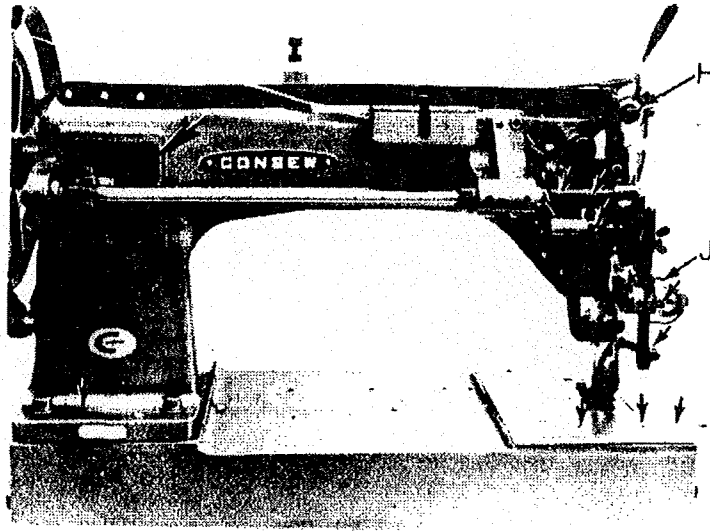

Fig. 11 Oiling Points at Back of Machine

On the back of the arm is a cover, fastened by two knurled screws loosen the screws and remove cover. Care should be taken to see that all the moving parts inside are sufficiently lubricated. Replace cover into position and tighten the two screws.

SECTION III

BASIC ADJUSTMENTS

1. TO SET THE NEEDLE BAR

When the shuttle point is at the center of the needle, the top of the needle eye should be approximately (0.8mm) 1/32' below the point of the shuttle.

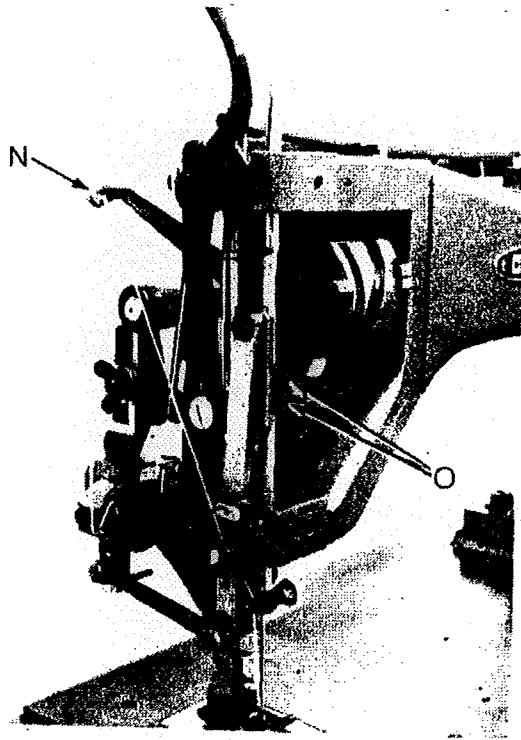

Fig.12 Setting the Needle Bar

To adjust, loosen the two set screws "O" Fig. 12 and move the needle bar up or down as required, then securely tighten the set screws.

NOTE - This setting of the needle bar may be varied slightly depending upon the size of the needle and the thread being used.

2. TO SET THE SHUTTLE WITH RELATION TO THE NEEDLE

The shuttle can be adjusted for proper clearance between the shuttle point and the needle. If a change is made from a very small needle to a much larger one, the shuttle point will perhaps pass too close to the needle, or too far away from it, if the change is from a large to a much smaller needle.

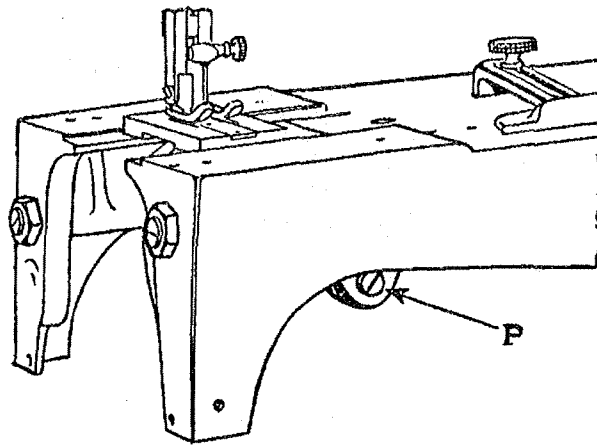

Fig. 13 Setting the Shuttle with Relation to the Needle

In such cases, loosen the clamping screw (P), Fig. 13 beneath the machine bed, and move the shuttle race slightly to right or left to suit the needle being used, then securely tighten the clamping screw (P).

3. TO TIME THE FEED

For general sewing conditions, the feed do should be so timed that it will have completed its feeding action at approximately the same time that the take-up lever N Fig. 12 completes its upward stroke.

When the machines leave the factory **THEY ARE PROPERLY TIMED, AND NO ADJUSTMENT IS NECESSARY UNLESS THE POSITION OF THE FEED CAM HAS BEEN DISTURBED.**

If adjustment should be considered necessary, remove the arm side cover at the rear side of the machine arm. The feed cam is easily accessible with the arm side cover removed.

This cam is provided with two screws. Loosen these two screws and set the cam for earlier or later movement of the feed dog, as required, by turning the cam about the arm shaft to the required position, then securely tighten the two screws in the cam.

4. HOW TO SET HANDWHEEL

The handwheel (35008) is packed separately and must be positioned on main shaft prior to operating the machine.

Remove the two screws (35009) and slide off the bushing that is set on the shaft. Then set the handwheel on the shaft using the two bushing screws 35009. See Fig. 14.

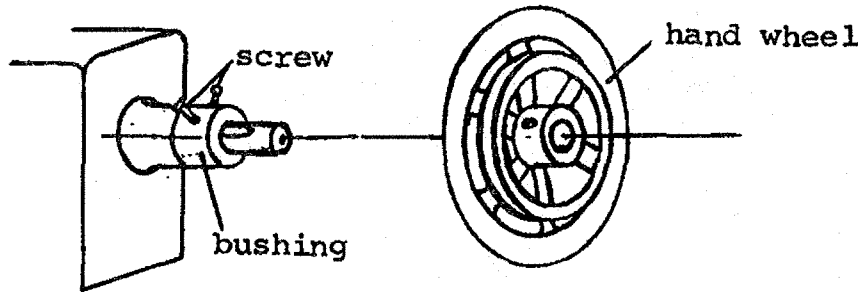

Fig. 14 Setting the Handwheel

SECTION IV

TROUBLE SHOOTING

This section contains trouble-shooting information which can be of help in determining and removing the causes of trouble that may develop in the machine. When the troubles covered by this section develop, they can be conveniently tracked down and readily corrected by consulting the following tabulation:

SYMPTOM	CAUSE	REMEDY
Needle breakage.	Needle is loose in needle clamp.	Tighten needle clamp.
	Needle of incorrect class and style is being used.	Compare needle with one of correct type.
	Presser foot is loose or out of line.	Straighten and align presser foot; tighten securely.
	Needle is too light for material being sewn.	Select the correct needle.
	Operator is pulling the material being sewn.	<u>DO NOT</u> assist machine in feeding of material.
Thread breakage (Needle).	Thread is too heavy for needle being used.	Select and insert a thicker needle.
	Right twist thread is being used.	<u>Only left twist thread</u> is to be used.
	Damp or defective thread is being used.	Use new, dry and smooth thread of correct size.
	Machine is incorrectly threaded.	Follow threading diagram as shown.
	Needle is incorrectly set.	Set the needle with the short groove closest to the loop taker (shuttle).
	Upper tension is too tight.	Adjust for correct stitch balance.
	Thread take-up spring is out of adjustment.	Adjust to proper position.

SYMPTOM	CAUSE	REMEDY
Thread breakage (Needle) (Continued):	Needle is rubbing against presser foot.	Re-align and tighten presser foot.
	Needle is defective, blunt or bent at point.	Replace with new needle.
	Sharp edge on the loop taker (shuttle), bobbin case or tension controllers.	Smooth with fine emery paper and polish with rouge cloth.
Thread breakage (Bobbin)	Damp or defective thread being used.	Use new, dry and smooth thread of correct size.
	Bobbin thread tension is too tight.	Adjust for correct stitch balance.
	Bobbin shuttle case is incorrectly threaded.	Follow threading instruction as described.
	Bobbin is wound too full to revolve freely.	Remove excess thread to the rim of the bobbin. Adjust bobbin winder accordingly.
	Rounds of thread on the bobbin are lapped over one another.	Unwind bobbin manually and rewind evenly and uniformly.
	Bobbin case is sticky with gummy oil and lint.	Clean bobbin case, shuttle and shuttle race with kerosene or naphtha, then lubricate with a few drops of oil.
	Sharp edge on shuttle, bobbin case, bobbin or needle.	Smooth with fine emery paper and polish with rouge cloth.
Skipping (skip stitches)	The needle thread fails to catch the bobbin	Reset the needle bar and needle as described.
Drawing of Seam.	The threads draw or pucker the seam.	Adjust tensions for correct stitch balance.
Stitches uneven or piled up.	Stitches pile up in one place.	Adjust stitch regulation for longer stitch.
		Increase presser foot pressure.

SECTION V

PARTS LIST & ILLUSTRATIONS, MODEL 733R SERIES

NOTES:

PARTS LIST

1. Arm Shaft, Takeup Lever, Needle Bar and Feeding Mechanism.

PART NO	QTY	DESCRIPTION	PART NO	QTY	DESCRIPTION
4019	1	Screw	35158	1	Spring
4135	1	Nut	35167	1	Cover
6027-2	1	Nut	35168	1	Cover
6037	1	Screw	35201	1	Connecting Rod
8040	3	Screw	35202	2	Cap Screw
8093	2	Screw	35203	1	Hinge Screw
8105	1	Nut	35204	1	Nut
17053	1	Screw			
17059	1	Screw	35045	1	Stitch Reg. Cam
17061	1	Setscrew	35046	1	Stitch Reg. Fork
35006	1	Collar	35047	1	Stitch Reg. Fork
35009	2	Screw			Link
35010	1	Armshaft	35048	3	Screw
35011	1	Bushing			
35012	1	Setscrew			
35013	1	Oil Cup			
35014	1	Oil Cup			
35016	1	CAM			
35017	4	Setscrew			
35018	1	Tapered Pin			
35019	1	Link			
35020	1	Hinge Screw			
35021	1	Stud, Conn., Needlebar			
35022	1	Needlebar			
35023	2	Bushing			
35024	1	Needle Clamp			
35025	1	Screw, Needle Clamp			
35026	1	Needle			
35033	1	Casting insert			
35034	3	Screw			
35035	1	Lever, Thd. Takeup			
35036	1	Hinge Screw			
35038	1	Nut			
35039	1	Screw			
35040	1	Washer			
35049	1	Arm			
35050	1	Fulcrum Pin			
35051	1	Stud, Stitch Reg.			
35052	1	Plate			
35053	2	Screw			
35054	1	Washer			
35055	1	Nut			
35056	1	Nut			
35057	1	Ball Handle			
35058	1	Spring			
35059	1	Plate			

1. RELATIVE PARTS FOR ARM SHAFT, TAKE UP LEVER, NEEDLE BAR & FEEDING MECHANISM

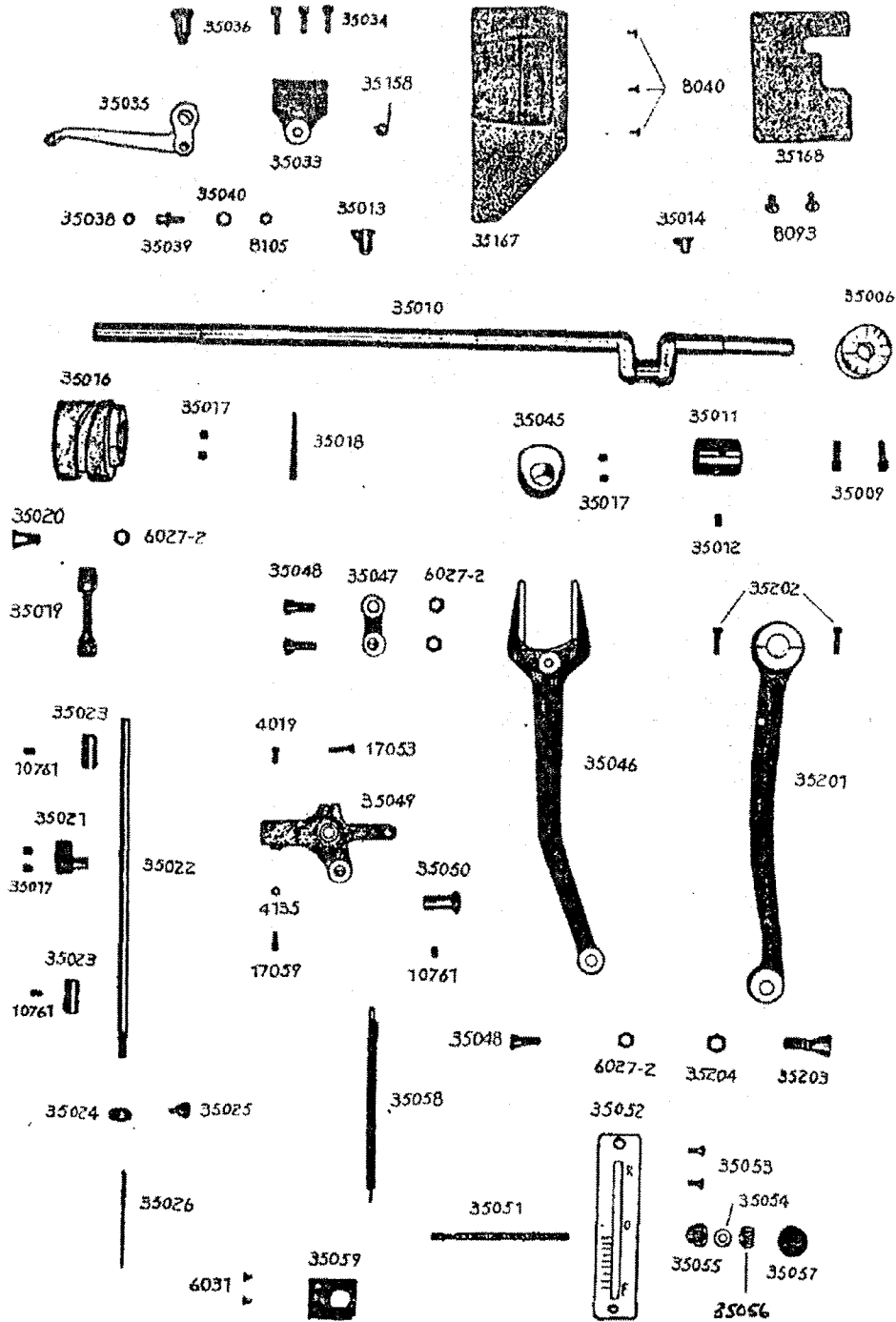

PARTS LIST

2. Upper Feeding Mechanism

PART NO	QTY	DESCRIPTION	PART NO	QTY	DESCRIPTION
8097	1	Setscrew	35109	1	Shaft
8105	1	Nut	35110	1	Bracket
10519	1	Screw	35111	2	Screw
10524	2	Setscrew	35112	2	Pin
10525	1	Setscrew	35113	1	Arm
10566	2	Setscrew	35114	1	Pin
10581	3	Setscrew	35115	1	Crank
10598	1	Screw	35117	1	Nut
10683	1	Screw	35118	1	Washer
10685	1	Screw	35119	1	Hinge Screw
10776	1	Wing Nut	50174	1	Pin
35017	1	Setscrew	50295	2	Pin
35034	3	Screw			
35065	1	Crank			
35066	1	Bushing			
35067	1	Connecting Rod			
35068	1	Pin			
35069	1	Crank			
35071	1	Bushing			
35072	1	Shaft			
35073	1	Friction Washer			
35074	1	Bracket			
35075	4	Screw			
35076	2	Taper Pin			
35077	1	Sleeve			
35078	1	Crank			
35079	1	Screw			
35080	1	Sleeve			
35081	1	Block			
35082	1	Washer			
35083	1	Feed Bar			
35084	1	Pin			
35085	2	Collar			
35087	1	Saddle			
35088	2	Screw			
35089	2	Setscrew			
35090	1	Rod Connector			
35091	1	Screw			
35092	1	Screw			
35102	1	Strap			
35103	2	Screw			
35104	2	Nut			
35105	1	Screw			
35106	1	Nut			
35107	1	Spacer			
35108	1	Arm			

2. RELATIVE PARTS FOR UPPER FEEDING MECHANISM

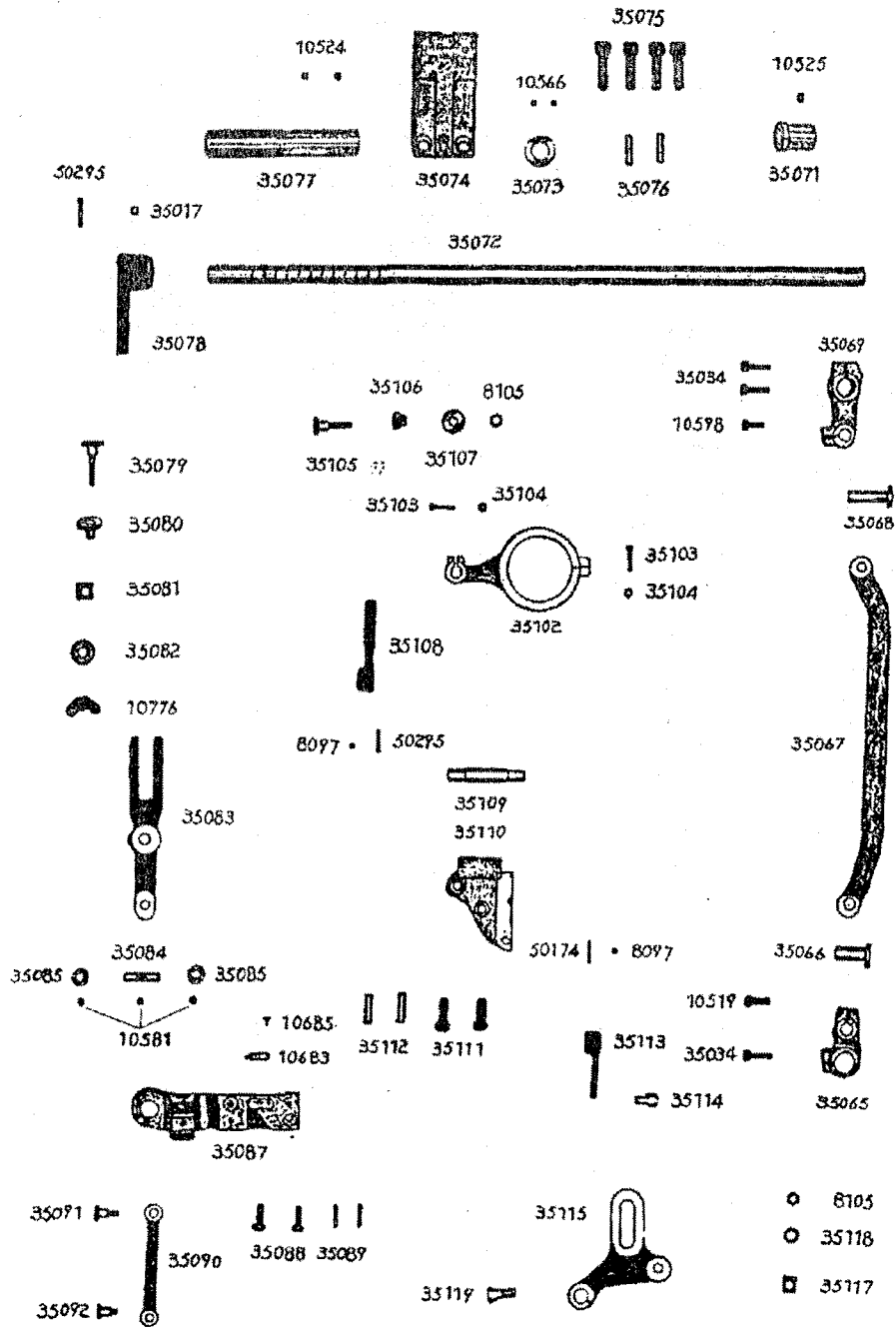

PARTS LIST

3. Presser and Thread Tension

Part No	Qty	Description	Part No.	Qty	Description
1422	1	Spring	35147	1	Lifter
1423	2	Tension Disc	35148	1	Hinge Stud
4171	1	Tension Screw	35149	1	Hinge Pin
4179	1	Pin	35150	1	Stud
6025	1	Screw	35151	1	Washer
6029	1	Screw	35152	1	Bar
6306	2	Screw	35153	1	Spacer
6333	2	Screw	35154	1	Screw
8009	1	Setscrew	35159	1	Eyelet
8079	2	Nut	35161	1	Check Spring
8089	1	Screw	35164	1	Thread Tens. Assy.
10559	1	Screw	35166	1	Spring Regulator
10571	1	Stud	50101	2	Screw
10581	1	Setscrew			
10586	1	Nut			
10712	2	Hinge Screw			
10761	1	Setscrew			
10827	1	Setscrew			
10828	1	Setscrew			
30025	2	Nut			
30078	1	Screw			
35023	1	Bushing			
35034	2	Screw			
35093	1	Link			
35094	1	Washer			
35096	1	Presser Foot			
35097	1	Screw			
35098	1	Nut			
35120	1	Bracket			
35125	1	Spring			
35126	1	Pin			
35127	1	Bracket			
35128	1	Bolt			
35129	1	Nut			
35130	1	Bracket			
35133	1	Spacer			
35136	1	Slide			
35137	1	Sleeve			
35138	1	Sleeve			
35138-1	1	Bushing			
35139	1	Hinge Bracket			
35140	1	Presser Bar			
35141	1	Presser Foot			
35145	1	Bracket			

3. RELATIVE PARTS FOR PRESSER & THREAD TENSION

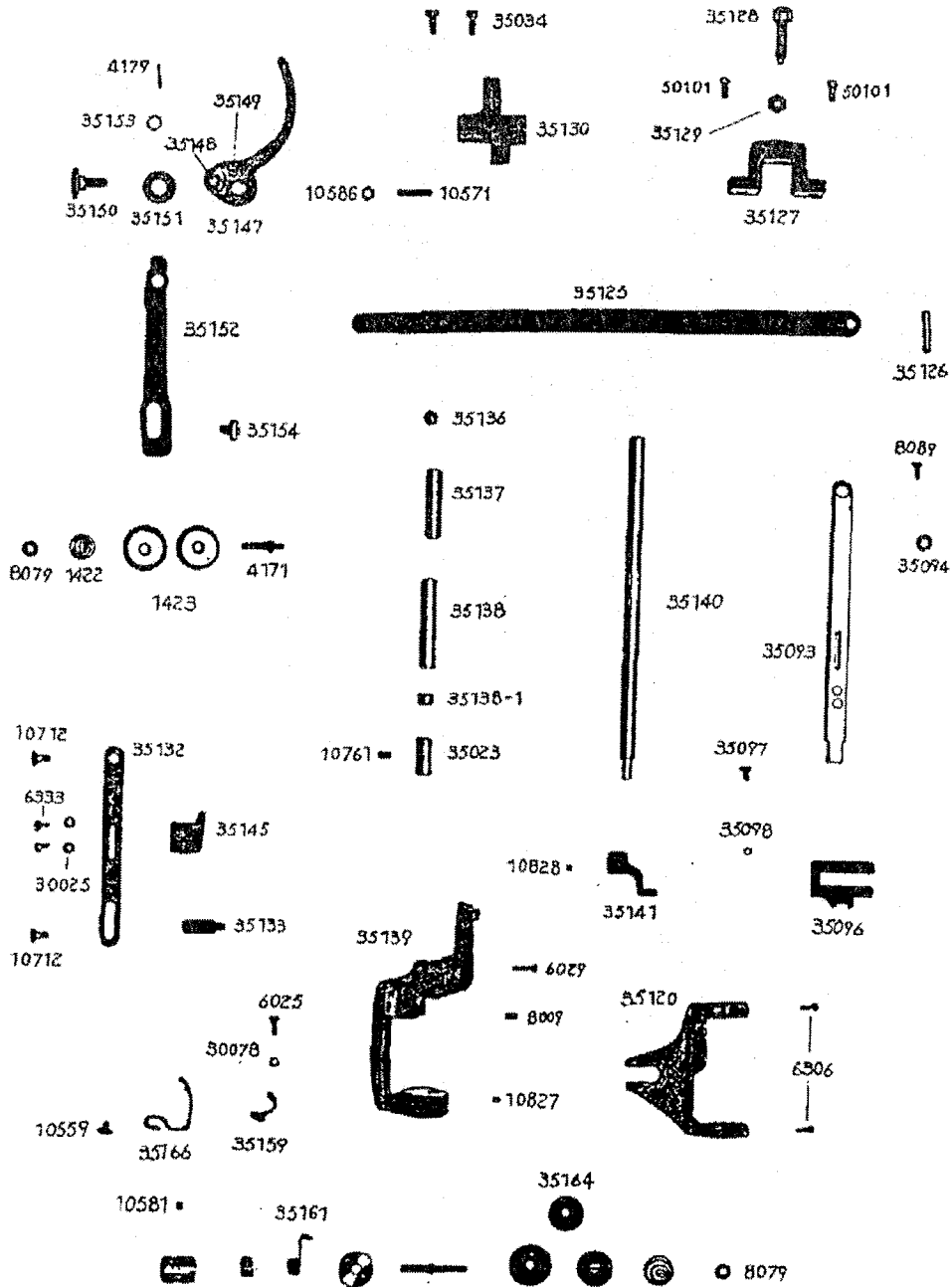

PARTS LIST

4. Lower Feeding, Needle Plate & Hook

Part No.	Qty	Description	Part No.	Qty	Description
1368	1	Screw	35224-1	1	Frame
6027-1	2	Screw	35224-2	1	Barrel
6027-2	2	Nut	35224-3	1	Opener
8009	2	Setscrew	35224-4	1	Pin, Hinge
12418	1	Screw	35224-8	1	Pin
35017	2	Setscrew	35226	1	Bobbin
35182	1	Crank	35232	1	Rock Shaft
35183	1	Screw	35232-1	1	Wear Block
35184	1	Feed Rock Shaft	35233	1	Crank
35185	2	Screw	35234	1	Screw
35186	2	Screw	35235	1	Setscrew
35187	5	Nut	50174	1	Setscrew
35188	1	Feed bar			
35189	1	Feed dog			
35190	1	Strip			
35191	2	Screw			
35192	1	Throat Plate Body			
35193	2	Screw			
35194	1	Work Plate			
35195	4	Screw			
35205	1	Rock Shaft, OSC			
35206	1	Hinge Pin			
35207	1	Stud			
35208	1	Packing			
35209	1	Oil Tube			
35210	1	Washer			
35211	1	Screw			
35212	1	Spacer			
35213	1	Nut			
35214	1	OSC., Shaft Crank			
35215	2	Pin			
35216	1	Shaft, OSC			
35217	1	Collar			
35218	1	Shuttle Driyer			
35219	1	Shuttle Race Frame			
35220	1	Screw			
35221	1	Setscrew			
35222	1	Shuttle Race Complete			
35222-1	1	Shuttle Race			
35222-2	2	Pins			
35222-3	1	Race			
35223-4	1	Spring			
35224-5	1	Screw			
35223	3	Setscrew			
35224	1	Shuttle			

1. RELATIVE PARTS FOR LOWER FEEDING, NEEDLE PLATE & HOOK

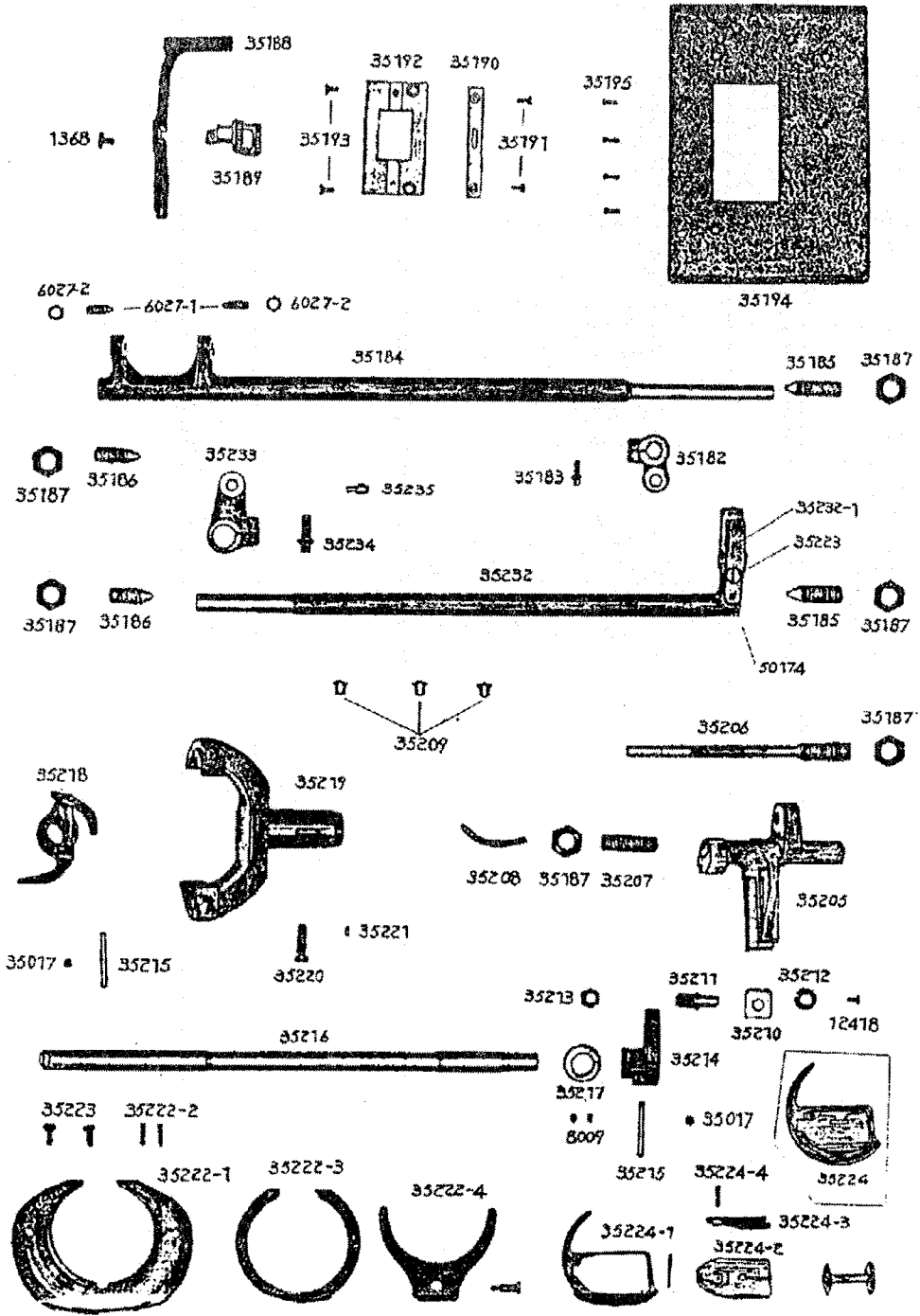

PARTS LIST

5. Balance Wheel, Belt Guard, Oilbox and Presser Lifter Lever

Part No.	Qty	Description	Part No.	Qty	Description
6339	6	Setscrew			
8100	3	Screw			
10519					
10699	1	Screw			
10712	1	Screw			
11154	1	Pin			
11371	1	Screw			
13005	3	Screw			
35008	1	Balance Wheel			
35009	2	Screw			
35131	1	Flat Spring			
35157	1	Oil Box Comp.			
35157-1	1	Oil Box			
35157-2	1	Cover Oil Box			
35157-3	1	Hinge Pin			
35157-4	1	Spring			
35157-7	2	Washer			
35157-8	1	Washer			
35157-9	1	Felt			
35223	1	Screw			
35239	1	Belt Guard Comp.			
35239-1	1	Cover, Belt Guard			
35239-2	1	" " "			
35239-3	1	Brace, Belt Guard			
35276	1	Spring			

5. BALANCE WHEEL, BELT GUARD, OIL BOX & PRESSER LIFTER LIFTING LEVER

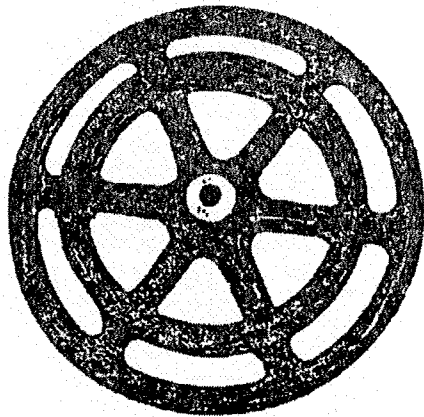

35008

† 10699

35157-2



35157-7

35157-8

35223 †

35157-3

† 8100



35157-9



35157-1

35157-7

† 8100

35157-4

† 8100



35009

10712 †

11154

35276

† 11371

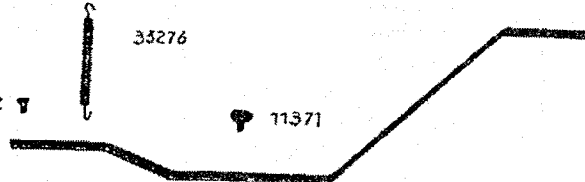

35131

35239-1

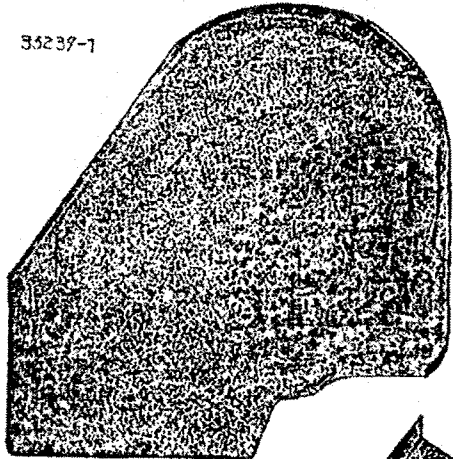

6339



35239-3

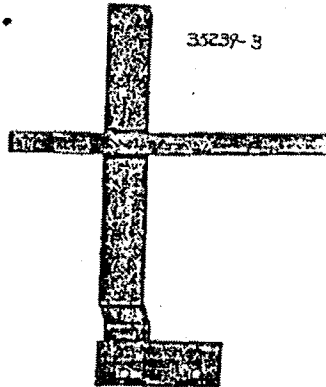

13005



35239-2

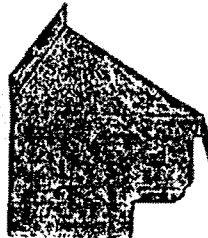

10317 †

† 13005

PARTS LIST

6. Accessories

Part No.	Qty	Description	Part No.	Qty	Description
0040	1	Nut			
0058	2	Washer			
1870	1	Wrench, Allen			
8118	1	Screwdriver			
8120	1	Screwdriver			
8123	1	Oil Bottle			
8132	1	Box, Accessories			
11376	1	Strap			
11377	2	Screw			
11378	2	Nut			
11379	2	Washer			
11571	1	Wrench, Allen			
35026	1	Needle			
35225	1	Opener			
35226	5	Bobbin			
35240	2	Bed Bracket			
35241	8	Screw, Bracket			
35254	1	Cotton Stand			
35255	1	Bobbin Winder			
35277	1	Chain			
35278	1	Chain			
35279	1	Chain			
35280	1	Presser foot lifter & feed reverse inter- mediate linkages, complete set.			
50296	2	Pedal Assy.			

6. ACCESSORIES



8132



35226



15571



1870



35026



35225



8129



8118



8120



0040



0058

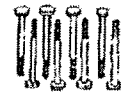

35241

35240

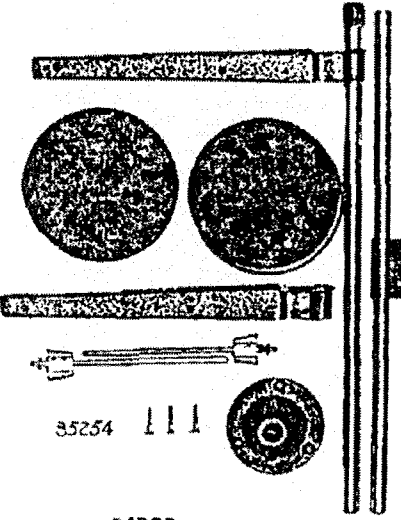
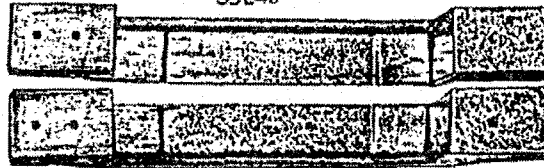

35254

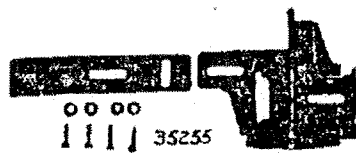

35255

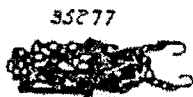

35277

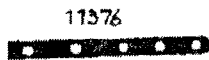

11376

50296



11378

11379

11377

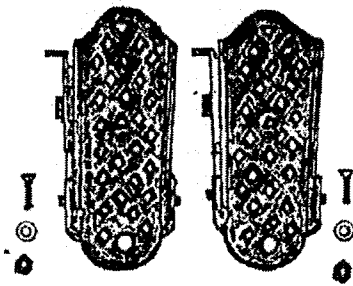

35278



35279

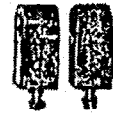

35280



**Consolidated Sewing
Machine Corp.**
Website: www.consew.com

MAIN office

131 W. 25th Street
New York, NY 10001
Tel: 212-741-7788
Fax: 212-741-7787
e-mail: consew@att.net

Miami, FL

4013 N.W. 79th Avenue
Miami, FL 33166
Tel: 305-471-0200
Fax: 305-471-0243
e-mail: miamisales@consew.com

Los Angeles, CA

2320 South Hill Street
Los Angeles, CA 90007
Tel: 213-745-8844
Fax: 213-745-8855
e-mail: lasales@consew.com